



**ALCON LABS:
PROJECT CHIRON**

Southern Methodist University

TEAM ALCON

C. Davis | C. Ngo | D. Nguyen | S. Ramdhanny

B. Luong

TABLE OF CONTENTS

I. EXECUTIVE SUMMARY3

II. PROJECT BACKGROUND & DEFINITION OF THE PROBLEM4

III. PROJECT DESCRIPTION4

 A. CORE OBJECTIVES.....4

 B. PROJECT PERSONNEL.....5

 C. MILESTONES6

 D. ACTION & APPROACH PLAN.....6

 E. ANALYSIS OF SITUATIONAL APPROACH.....7

 F. REVIEW AND EVALUATION PLAN.....12

IV. ANALYSIS AND MANAGERIAL INTERPRETATION.....12

V. CONCLUSION.....18

 A. RECOMMENDATIONS18

APPENDIX A: PROJECT SCHEDULE24

APPENDIX B: MODEL DOCUMENTATION25

APPENDIX C: EXCELLENT SUGGESTED READINGS.....27

APPENDIX D: PRESENTATION SLIDES27

I. EXECUTIVE SUMMARY

Alcon, Inc. has successfully progressed into a research and development-driven, global pharmaceutical company focused on eye care. The Company conducts its global business through two business segments: Alcon United States and Alcon International. In each business segment markets, Alcon discovers, manufactures, and markets its products principally into three product categories of the ophthalmic market: pharmaceutical (prescription ophthalmic drugs), surgical equipment and devices (cataract, vitreoretinal and refractive), contact lens care (disinfecting and cleaning solutions), and other vision care products (artificial tears). In this pipeline, these products dominantly serve eye care professionals and direct purchasers of its products, such as hospitals, managed care organizations, government agencies, and individuals.

At their main headquarters, located in Fort Worth, Texas, Alcon operates two manufacturing plants (North and South Quad), a corporate warehouse and distribution center, and a research and development facility. These two manufacturing plants serve regional, national, and international locations and contribute to the production of more than 10,000 unique products.¹

In one aspect of the Company, the Manufacturing and Technical Support group is primarily responsible for the development of Alcon's product pipeline and the timely delivery of these products. Other aspects include their Quality Assurance (QA), Corporate Engineering, Corporate Purchasing, Corporate Safety and Environmental Affairs, U.S. Distribution and Customer Service divisions. Overall, their synergistic activities involve an inherent objective that must optimally expand capacity, increase efficiency, and improve quality. Within their endeavors, Alcon also incorporates six sigma initiatives and continuous improvement.

As of October 2003, Alcon closed their Madrid (Spain) manufacturing plant and assigned its manufacturing responsibilities to Fort Worth (Texas). The Madrid product lines in addition to Fort Worth product lines have currently been in production with unacceptable inefficiencies, including loss in whitestock production and production time, packaging and labeling difficulties as well as capacity and scheduling issues.

The Southern Methodist University undergraduate engineering students (Team Alcon) volunteered to review current manufacturing operations and propose process improvements with the goal of achieving significant cost savings. The sole purpose of this project will be to observe, develop, evaluate, and implement management science concepts that will significantly support and impact efficiency levels.

For the most part, there are four stages involved in Project CHIRON²: 1) Observe and gather data; 2) Evaluate the current process and develop a model (or models) that realistically simulates the manufacturing environment; 3) Run the model(s) in several iterations; and 4) Develop and Identify solution(s). This particular milestone will be the most fun aspect of the project. Most importantly, we must review, analyze, interpret, and disseminate the results at each development stage.

In conclusion, we explored two perspectives to resolve the problem of production process inefficiency. For the short-term perspective, we discovered the source of the problem and the critical reasons for the cause of the inefficiencies. Further, we tackled the issue by incorporating the Single-Minute Exchange of Dies (SMED) method and generated solutions that would streamline Alcon Labs' manufacturing operations. For the long-term perspective, we investigated the option of converting the current two-step production process into an inline process in the future by building simulation models. Overall, by implementing our suggested recommendations, Alcon Labs will be determined to reap expected benefits.

¹ Specifically, Alcon produces and distributes ophthalmic solutions, suspensions and ointments, contact lens care and surgical solutions, knives and sutures, intraocular lenses, surgical equipment and accessories, refractive lasers, and custom procedure packs for ophthalmic surgery. **Source:** Company reports

² Chiron is from Greek mythology and one of the most famous/common asteroids. Chiron is a wise centaur who trained heroes. One day in battle, he was shot in the hip by a poisoned arrow. With this casualty that he never recovered from, he spent most of his life learning and practicing the healing arts. Chiron therefore stands for the Wounded Healer or Healing Journey.

II. PROJECT BACKGROUND & DEFINITION OF THE PROBLEM

In October 2003, Alcon divested their interests in the Madrid manufacturing plant. As a result, the Madrid's product baseline of 170 stockkeeping units (SKUs) and twelve million units were transferred to the Fort Worth manufacturing plant – mostly in very small order quantities. Before the Madrid divestiture, the Fort Worth manufacturing plant was producing 230 to 250 SKUs and 70+ million units.

The challenge is to evaluate the best way to manufacture these added units. In order to change labels, Alcon must stop the line and perform a line clearance (a federal regulation for drugs and devices) which may take up to 20 to 30 minutes (this is also called a 'split'). Then, they can restart with the new label, but at the same time, Alcon loses the capacity (units they would have filled) while the fillrooms are down during the line clearance.

Often, Alcon would have to do four to five line clearances per day so they take an efficiency hit. One suggested alternative is to keep the fillrooms running 100% of the time and produce whitestock (unlabeled product) and then label these products in an off-line operation (two-step process). So, the trade-off is an efficiency hit for line clearances or extra cost incurred due to the whitestock labeling process (bulking it off the line, storage, retrieval, then label and carton). Several issues include mass customization, capacity analysis, scheduling, layout and material movement, and optimal lot size production for these small order quantities to minimize the total number of packaging lots that Alcon produces (i.e. less frequent, but larger runs).

Specifically, the question remains whether Alcon has adequate whitestock labeling capacity. If not, Team Alcon will further evaluate and determine approaches that will address the issues mentioned above as well as incorporate as many lean manufacturing techniques as possible into this "label-to-order" operation.

III. PROJECT DESCRIPTION

Team Alcon has divided Project CHIRON into several tasks that will break these complex set of issues from a broad perspective into a narrower view by listing: core objectives, project personnel, milestones, action and approach plan, analysis of situational approach, and review evaluation plan.

A. CORE OBJECTIVES

Team Alcon has identified a few core objectives for the purpose of maintaining focus on the prevalent issues, and it establishes as a strategic framework for the development of production and operation research model(s):

Our primary objectives will focus on the following areas:

- Minimizing splits (i.e. line clearances, and/or QA)³
- Maximizing utilization of filler rooms

³ Changeover is the total process of converting a machine or line from running one product to another. Changeover time is the total elapsed time between the last unit of good production of the previous run, at normal line efficiency, to the first unit of good production of the succeeding run, at full line efficiency. (Shingo).

While these primary objectives will occupy most of the project time, we hope to accomplish our secondary objective:

- Optimizing the lot size (batch) or economic order quantity levels
- Optimizing the facility layout

By accomplishing these objectives, Alcon seeks to achieve significant cost saving. We will also expect to reap benefits that will impact Alcon as well as achieve these resulting outcomes:

- Improved uptime and process efficiency
- Improved capacity levels
- Improved overall throughput speed and other technical performance measures
- Reduced or eliminated inventory levels and other unnecessary costs
- Minimized idleness of employees (i.e. employee output efficiency)

Further, at this preliminary stage, as one of the most important issues, we must understand client requirements and goals so that vertical and horizontal communication between members is kept crystal clear. So forth, there may be a few issues that may still be left unresolved, such as quantifying goals or misinterpretation of objectives and requirements.

B. PROJECT PERSONNEL

Several key players will contribute to the success of Project CHIRON. They include Dr. John Via, John Wilmoth, the Fort Worth Alcon Management Team and Support Team, Dr. Richard Barr, Benjamin Luong, Christopher Davis, Cuong Ngo, Cindy Nguyen, and Shanta Ramdhanny.

Dr. John W. Via, III, P.E.
Director of Manufacturing
Consumer Products Division

Mr. John Wilmoth
Project Manager
Consumer Products Division

Fort Worth Alcon Management Team and Support Team

Dr. Richard Barr is an Associate Professor as well as the Engineering Management, and Information Systems (EMIS) Chair at Southern Methodist University (SMU). Dr. Barr will greatly enhance the learning aspect of the project and will serve as Team Alcon's project advisor.

Benjamin Luong will graduate this year with Bachelor degrees in Management Science and Finance as well as a Masters degree in Systems Engineering. With a broad background, Mr. Luong's expertise lies in leadership and management, in which he serves as a leader for Tau Beta Pi, other campus organizations, and community care projects. He also serves as a healthcare analyst for the Ann Rife Cox Endowment Fund at SMU.

Christopher Davis is a senior Management Science student at SMU. He also has minors in Mathematics and Economics. Currently, he serves as the Campus Ambassador for Nortel Networks and was recently chosen to be a SMU Student Foundation Campus Ambassador for 2004-2005. After graduation, he plans to complete his Masters of Science degree in Engineering Management in May of 2005. Mr. Davis' expertise is developing quantitative models to examine the efficiency of a process.

Cuong Ngo is also currently a senior at SMU. He is doubling majoring in Management Science and Mathematics with a specialization in Operation Research. With knowledge in mathematics and management science, his expertise lies within the fields of engineering, business, and statistics.

Diem Nguyen is a double major in Management Science and Math with specialization in Operations Research. She especially enjoys working with linear programming models, integer programming models, and network models. She has successfully completed numerous EMIS courses including Production Management, Operations Research, and Systems Analysis and Design but seeks to learn more. She is extremely fond of her field of study and is contemplating furthering her studies, such as seeking a Masters Degree in Systems Engineering or Operations Research.

Shanta Ramdhanny is a senior at SMU, who will graduate with a Bachelors in Management Science and a minor in Mathematics. Within the SMU community, she plays an important role as a team member of the women's basketball team.

C. MILESTONES

During the course of the project, we have indicated several milestones that determine our success. Our milestones depend on completing the project plan, the mid-term presentation, the working model(s), the final report, and the final presentation. Please view Appendix A for a detailed description.

D. ACTION & APPROACH PLAN

Our proposed solution(s) will require the use of several interrelated factors and sample data that will be thoroughly analyzed for the development of working model(s) and for its feasible future implementation:

- Demand forecasting schedule, containing historical demand data for purposes of simulation runs and inputs to linear programming and queuing models
- Historical production months (comparison: in-line vs. 2-step operations)
- Production Process charts, diagrams, flowcharts, maps, etc.
- Material Requirements Plan and order schedules (MPS – finished goods schedule)
- Accounting cost schedule for current and past operations (EOQ on splits/production)
- Throughput speed and other performance measures on current lines for each shift to analyze for areas of improvement (i.e. computer readings)
- Employee output efficiency – measure employee contribution
- Previous proposed solutions and previous analyses

We will also collect certain data throughout the course of the project. However, any available sample data and assistance will expedite completion of the project.

E. ANALYSIS OF SITUATIONAL APPROACH (ASA)

Our situational approach to the problem will comprise of examining and processing a short-term approach and a long-term approach to develop short-term and long-term solutions.

ASA: SHORT-TERM APPROACH

For the short-term immediate impact, we will begin observing and measuring the “splits” process steps for cycle time improvements. On Whitestock Line 1 (Kit 1) and Whitestock Line 2 (Kit 5), we will record the “process” or sequence of repeatable activities with measurable inputs, value-added activities, and measurable outputs. As a result, the process view will give a wider, cross-functional view of the business, lead to an understanding of the total process, and help see the tradeoffs across functions.

Also, by observing and measuring the duration of these activities, we expect to improve cycle time or changeover/roll-over time by reorganizing and reducing setup activities as well as resources and inventory waste and rescheduling production schedules for low quantity batches while sustaining high product quality.

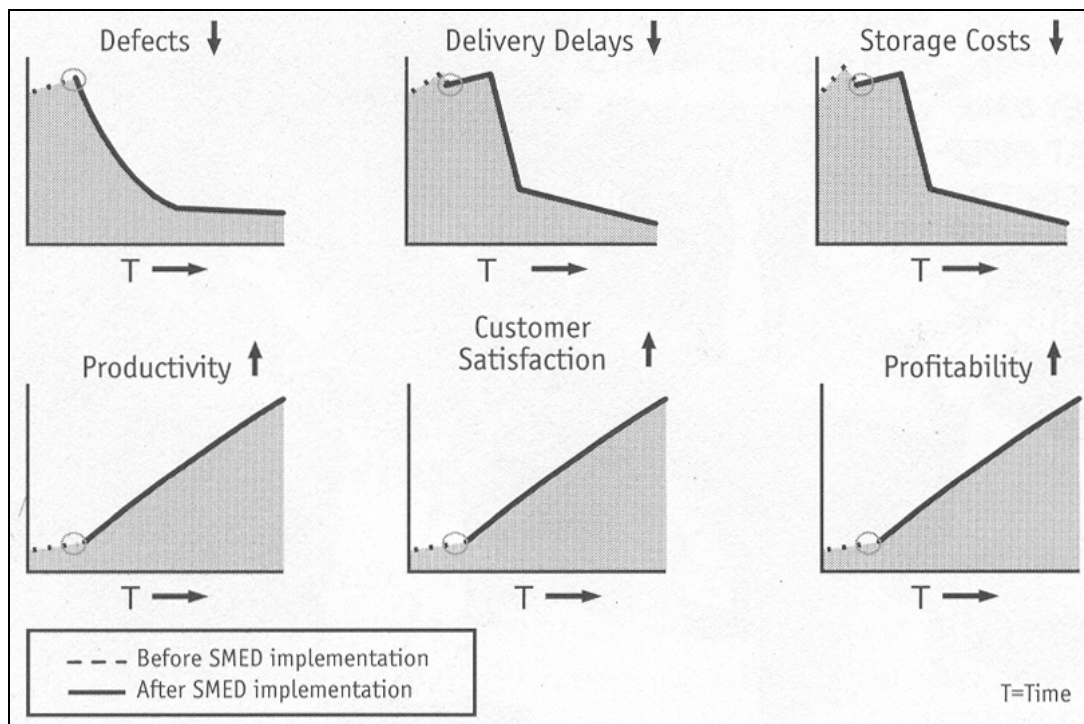

Exhibit 1: SMED Benefits

Source: Shingo, 1996

Other benefits of setup reduction include lower cost (less inventory), better flexibility, better worker utilization, shorter lead time, increased capacity, and most importantly, less process variability. Please see Exhibit 1 for a visual interpretation of Single-Minute Exchange of Dies (SMED) Benefits. Therefore, we begin by reducing setup time as an objective rather than the objective of lean manufacturing. Additionally, lean manufacturing is supported by setup reduction and is the driver for when and where we apply setup reduction. As another important concept, setup reduction covers not only the replacement of tooling and production parts, but also other operations, such as the revision of standards and replacements of assembly parts and other materials.

ASA - Short-Term Approach: Technical Description of Approach

Some applicable techniques that will be helpful for analyzing the problem are the Process Analysis Technique (PAT) and the SMED method developed by Shigeo Shingo. With Single Minute Exchange of Dies, Shingo's methodology has historically changed process tooling in nine minutes or less from an old process of four hours or more. But, each technique specifically focuses on locating the source of the problem that exists in production process activities and setup time and presents ideas on how to resolve these conflicts. Activity steps will be intimately looked upon for process improvement and setup time/cycle time reduction. Once a streamlined, process step solution has been developed, the end result – quick changeovers – will be a strong, flexible manufacturing operation that will be adaptable to changes. Delays, downtime, and low productivity levels will hopefully cease to be a significant, recurring problem.

According to Exhibit 2, there are three stages involved in the SMED process for changeover improvement. *Stage One* requires separating internal and external setup activities. **Internal setup activities** involve elements in the changeover that can only be executed when the machine is stopped. **External setup activities** involve elements that can be done when the machine is active. *Stage Two* requires converting internal setup to external setup activities by passing two important phases. First, we reexamine operations to determine whether steps in the process are incorrectly assumed to be internal setup. Second, we develop ways to convert these steps to external setup. For example, we can prepare and transport materials while the whitestock lines are operational; thus, these behaviors will cut time by as much as 30 to 50 percent involved in internal setup. *Stage Three* requires streamlining all aspects of setup activities by implementing parallel operations, functional clamps, and mechanization as well as eliminating adjustments. We streamline operations by improving external setups.

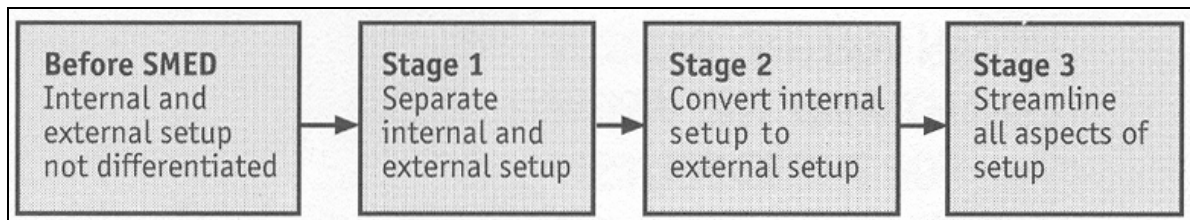

Exhibit 2: SMED Process

Source: Shingo, 1996

Additionally, there are four classifications of setup activities, according to Shingo:

- Type 1
 - Gathering, preparing, and returning tools, fixtures, etc.
- Type 2
 - Removing previous setup, mounting next setup on machine
- Type 3
 - Measuring, calibrating, adjusting
- Type 4
 - Producing test pieces, further adjustment until parts are good

ASA: LONG-TERM APPROACH

In general, one long-term approach of tackling the problem would be utilizing a combination of queuing models and simulation techniques. The benefits of simulation techniques provide the ability to create and develop dynamic scenarios with meaningful results. For instance, a single line with multiple servers would enhance efficiency and utilization of the fillrooms. Thus, throughput speed would increase significantly. Also, there would be a decrease in accumulation of whitestock, which would allow the fillers to continuously operate at an optimal capacity. After the bottles are filled, capped, and tamper-proofed, they enter a line with multiple servers. Each server would contain labels of different languages. Perhaps, we could assign one server to handle domestic whitestock and the other international whitestock. In this case, once the labels are depleted to satisfy the demand for one country, that particular server would temporarily stop while the labels would then be replenished or switched out. Meanwhile, the other servers would continue to run. Operating the lines with varying batch sizes ensures multiple lines would not be simultaneously inoperable. Otherwise, we would have to stop the line to replenish the labels. As a result, this procedure would theoretically minimize the number of line clearances or changeovers. With the additional labeling queues, the benefits would include continuous flow of products that allows for uninterrupted use of the fillrooms, decreased holding costs, increased output, and faster throughput.

In addition to extra servers, we would like to examine the production and order schedules to observe for any possible improvements. For example, if several different orders are placed for a similar product, perhaps the orders can be grouped together and filled collectively, to minimize the amount of changeovers or splits incurred. This would ultimately depend on the time frame that is allotted between the point when the order is placed and the time the order must be shipped. The frequency of changeovers contributes to the inefficiency of production, due to line clearances, reprogramming all of the labeling and safety sealing equipment, and constant redeployment of the workers. When working with a consistent product, it's much easier to work up a clean rhythm. We believe that the combination of additional strategically placed labeling queues and batch processing would improve overall efficiency tremendously. However, we must keep in mind of the fact that this solution may raise cost issues.

ASA - Long-Term Approach: Technical Description of Approach

We have defined the technical descriptions for two simulation models: Current and New process (See Appendix A for the simulation model logic).

Simulation Model: Current Process

The first phase of the simulation modeling process was to observe and evaluate the actual planning and manufacturing processes at Alcon Labs. We focused our attention on Kits 1 and 5, which were perceived to have the most inefficiencies. Kits 1 and 5 are specifically designed to perform labeling, cartoning, inserting, and packaging of whitestock, and filling and capping functions are performed at a separate area.

After thorough observation, we then proceeded to replicate the production process using simulation modeling software, ProModel. The first step was to organize the layout of both kits and define the locations, consisting of:

- 13-15 line workers
- series of conveyors
- labeler/scanner
- magazine/cartoner
- shrink-wrapper
- packaging

The second step was to create product entities that emulate the variation of whitestock product that is run on both kits. A variety of bottles in different shapes, sizes, and batches are routed to these lines. For simulation purposes we utilized different colored bottles to represent different batches of products.

The third step, involved the formulation of network paths, which, route and integrate the sequential line components using process nodes. Each node represents a particular process within the operation, and entities are routed along the specified path. Interfacing relations are assigned to consecutive components within the line.

The next step was to derive the process logic to portray the movement of entities, and the time allotted for processing at each particular location. Entities are identified as inputs as they enter a particular location, at which point a respective production process is performed, and a modified entity is output. The process is repeated continuously as the units move along the conveyor. Movement of units along the conveyor is expressed as a uniform probability distribution.

Arrivals are introduced into the system at the initial entry section of each line. This would be at the labeling location positioned at the beginning of each line. The arrivals essentially are batches of whitestock that are transported to the area on pallets, waiting for production. A quantity is specified for each batch of arrivals and is processed based on priority.

A setup downtime is incurred each time a new product enters a production line. During each changeover, machines are recalibrated, labelers and cartoners are replenished, line clearances are performed, and printers are reset. For simulation purposes, the average times pertaining to each location changeover process is used and during this period, workers and machinery appear to be idle.

Simulation Model: New Process

The next task was to conceive a manufacturing layout plan, which would improve the current process, and to build a simulation model based on that plan. Since the current method consisted of a two-step process of filling in one area, storing, and then brought over to Kits 1 and 5 area for labeling, cartoning, etc., we wanted to evaluate the effectiveness of creating an in-line process. Theoretically, this would enhance efficiency, increase production speed, eliminate or decrease product movement and handling, and the need for storage. This would be achieved by attaching a filler machine to both lines. The filler would only be able to accommodate one line at a time, while the other line performs whitestock operation and thereby, creating the ability for either kit to run in-line or two-step, but not simultaneously.

Thus, we began to build our model. The physical elements and functions of the current lines remain pertinent to the solution model. The central concept of this plan is the addition of a

filler attached to both lines. Therefore, there is no need to duplicate the locations and attributes of the previous model. We will simply merge and reuse some aspects of that model, and make the necessary additions and modifications to it. So, once again, we started by defining locations, the additions consisted of:

- filler
- capper
- tamper-proof
- accumulation
- series of conveyors

The next step was to modify the product entities that relate to the new system. With the addition of a filler, we had to create additional entities to symbolize unfilled/filled, uncapped/capped, untampered/tampered bottles, to properly represent the attributes of units deriving from the filler.

We then made changes to the network paths, to include the aforementioned locations and process nodes. We also added the interfacing relations to the processing logic to determine the routing procedures pertaining to the specific product and/or production schedule. This routes the product to the correct kitting line operation. This now brings the model to a total of four network paths, two network paths for in-line filling that then go on to two separate kitting destinations, and two network paths that correspond to whitestock entering the system from a remote location.

The processing logic was defined using the same methods, which were used in the previous model. Processing times were defined for the filling, capping, and tamper-proof operations, and movement was expressed as a uniform probability distribution.

The next modification was the arrivals method. We changed the arrivals locations, so that whitestock would now be coming from either the filler or the labeling locations on a pallet. Those coming from the filler represent an in-line operation, while those arriving to the labeling location are a two-step operation.

Setup downtimes were duplicated from the previous model as well. In addition the setup times for the newly integrated filler, capper, and tamper-proof machines were incorporated into the process. Overlapping changeover times can occur at these particular locations concurrently, due to the two lines sharing one filler. But this can be avoided easily with efficient product scheduling.

We then incorporated an additional sequence of conveyors that feed to the optional flex pack line. Automated insertion of packet literature and/or lens cases can be performed here. The “Flex Line” has access to this feature. This addition was not simulated in our model, but is shown as a visual.

In this model, we made the following assumptions:

- Setup times for each machine were calculated using an *average* from the statistics provided.
- Simulation images are not to scale.

- Simulation models are programmed to run at particular *overall* speed as opposed to individual *actual* speeds.
- Offline filling and storage time and activities are not accounted for in the simulation model.
- The proposed filler speeds and product specifics are assumed to be similar to the current equipment capabilities.
- When locations and resources appear to be idle, setup downtimes are in occurrence.

F. REVIEW AND EVALUATION PLAN

Upon completion of the fully-developed working model, we will test and evaluate the model to ensure a higher degree of confidence in the results. With the application of simulation techniques, we can accomplish a great deal, such as evaluating system layouts, component relationship and interfaces, and ultimately verify that the system met its initial set of requirements. Further, the simulation techniques will be tweaked to accurately imitate other manufacturing environments, such as in-line and two-step processes. Throughout this process, more data are collected and analyzed, and the results are compared with the specified requirements. The results obtained will be used as a comparative measure for effectiveness, efficiency, and supportability. Also, critical technical parameters, such as utilization, idleness, throughput speed, and capacity levels will be reviewed for performance purposes.

IV. ANALYSIS AND MANAGERIAL INTERPRETATION (AMI)

Upon observing Alcon Labs manufacturing operations, we discovered that there are six main process and operation steps (regarding the short-term approach). Please see Exhibit 3 for a general description of phases of a process where Line Clearance will presume the place of Inspection and also occurs between Transport and Processing.

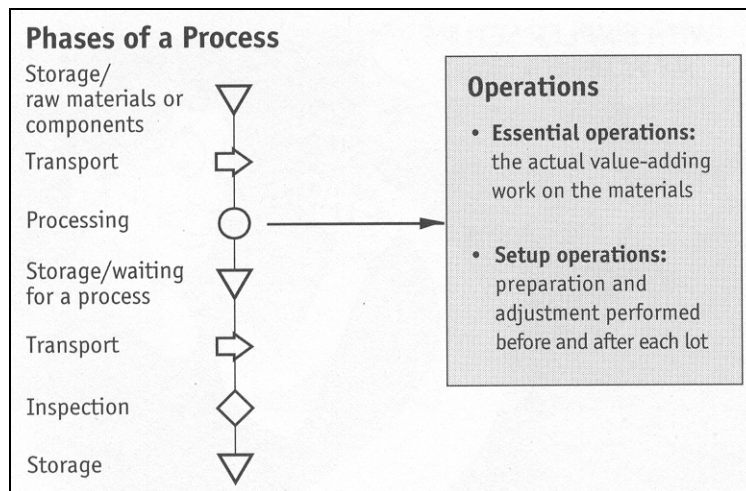

Exhibit 3: Phases of a Process

Source: Shingo, 1996

We also discovered that four general steps in setup generated the total changeover/rollover time on the whitestock lines (see Exhibit four). In fact, total changeover time negatively affects efficiency rather than line clearances. In Alcon Labs’ situation, the true depiction for the proportion of total changeover time actually reflects 10% of the time for preparation; 5% of the time for mounting labels, cartons, printer, wrapper, and case packer; 20% of the time for

measurements, settings, and calibrations, and 65% of the time for trial runs and adjustments (see Exhibit five). So, our additional core objective will be to minimize changeover time.

Exhibit 4: Proportion of Setup Times Source: Shingo 1996

Steps in Setup	Proportion of Setup Time Before SMED Improvements
Preparation, After-Process Adjustments, Checking of Materials and Tools	30%
Mounting and Removing Blades, Tools, and Parts	5%
Measurements, Settings, and Calibrations	15%
Trial Runs and Adjustments	50%

While trial runs and calibration times are separated as shown in Exhibit four and five, they actually represent a total of **85%** of the time regarding changeovers. Thus, the observed key inefficiencies and downtime from the Whitestock lines are the end results from setting up the equipment and then performing trials runs, vice-versa. Total observed changeover times have exceeded from 30 minutes to over four hours. Additionally, special orders seem to also be the cause for the number of changeovers occurred or required daily.

Exhibit 5: Alcon Labs- Changeover Times
Alcon Labs Setup Time Allocation

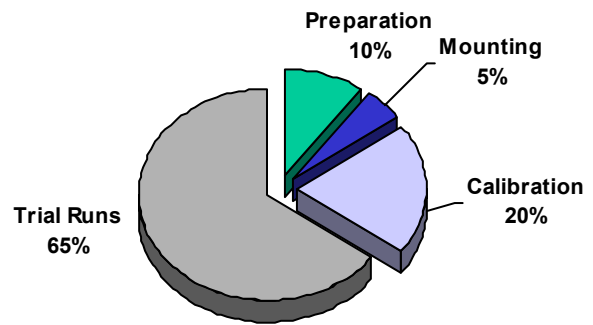

In the long-term approach, adding a filler room and a connection to the flex pack line to both Kit 1 and 5, would give us a proposed, new line called the “Flex Line.” Using simulation models to justify as visual evidence, this would be the anticipated long term solution. The simulation models are ideas that are not only theoretical but also general as well. Overall, these simulation models will illustrate how the concept of the “Flex Line” would improve the production efficiency and propose converting the current two-step process to an inline process.

AMI: SHORT-TERM APPROACH

As mentioned above, there are six key process steps to a successful manufacturing production on the whitestock lines: (1) Staging (storage) Area; (2) Line Area; (3) Changeover; (4) Production (5) Finished Goods Area; and (6) Reconciliation with the Materials Office. Process step one and two can be regarded as a Line Clearance function. On a whitestock line, there are generally 13 to 15 operators working and a total of four MBR (Manufacturing Batch Requirements) personnel that rotate weekly by shift. For the purposes of conciseness, the following are some of the most important procedures that are performed on the whitestock lines. For an elaborate list of procedures, please refer to the Alcon Labs Standard Operating Procedure (SOP) for Packaging and Line Clearance (PLC), version 3.0.

1st process: Staging (storage) Area

- Bill of Materials items are transported to whitestock line area from warehouse
- Obtain MBR sheet and Bill of Materials (usually 8 items): follow assembly and packaging instructions and cross check items on the floor
- Look and confirm lot code and part number on shippers (package boxes), medicine (product), inserts (lens cases), and film and label materials
- Catch all upstream mistakes

2nd process: Line Area

- Input information from MBR onto work boards
- Change lot codes and expiration date in 3 different areas (labelers, cartoners, and packaging)
- Check for misplaced bottles and items on line
- Clear the line of finished goods for preparation of new batch

3rd process: Changeover (see below)

4th process: Production

- Raw materials are fed into whitestock line for production

5th process: Finished goods

- Place proper labels on finished goods (boxes)
- Transport to intermediary area for later transport to warehouse
- Perform Post-Line Clearance and obtain sample for documentation and archives

6th process: Reconciliation

- Material Office performs a product check
- Before finished goods are placed onto loading trucks, Material and Reconciliation administrators perform weight checks to account for all materials used
- Usually, there is a discrepancy with the weight checks because the wasted materials, such as labels and rejected bottles, encountered during trials and adjustments are not accounted for the total weight check (this time delay may consume up to a maximum of 3 days, depending on the product)
- Finally, there is a product release, and the products are transported onto the trucks for shipment

Changeover Process: There are five main areas or functions for trial runs and adjustments – Labeler, Cartoners, Magazines, Ink Jet Coder (needed when necessary), and Wrapper/Packaging. Lists of important, required adjustments are mentioned in each function.

- **Labelers:** (Task duration = minimum of 30 minutes to a maximum of 1.5 hours; 45 minutes on average)
Several adjustments needed to be made:
 - Speed screw
 - Speed adjustment (precision fork) and overall speed of labels
 - Rails and pads (beginning and end of the system)
 - Height of labelers (3-4 pages: very long time)

- Wheels, motors, and torque adjustments
 - Bypass system (2 steps): vacuum chamber adjustment
 - Column guides that control the lot code picture snap
 - Tape Machine
 - Vision system (3 photo isles): teach it to track product model, lot codes, and expiration date
 - Test trial
- **Cartoners:** (Task duration = minimum of 30 minutes to a maximum of 1 hour)
Several adjustments needed to be made:
- Length of spore line
 - Break loosen and tighten screws at the beginning and end
 - Belt that snug incoming cartons
 - Fingers to properly hold cartons (may cause skewness in closing cartons if not adjusted correctly)
 - Rails of machine and flaps of carton (top and bottom)
 - Test trial
- **Magazines:** (Task duration = minimum of 30 minutes to a maximum of 2 hours)
Several adjustments needed to be made (may be difficult depending on carton dimensions):
- Bolts (positioned in different areas)
 - Bolts that hold the magazine chain (tighten/loosen)
 - Height of carton, vacuum, and placement
 - Flap bar (top and bottom) for printing product information and glue completion (may cause the most problem with skewness of carton)
 - Spindle wheel for closing flaps (beginning and end)
 - Test trial
- **Ink Jet Coder (when needed for some products):** (Task duration = 30 minutes)
Several adjustments needed to be made:
- Spray printer head that sprays lot code onto carton on the spore line
 - Enter lot code, exp date, and other data into print screen memory
 - Insert correct ink into printer
 - Test trial
- **Wrapper/Packaging:** (Task duration = minimum of 35 minutes for a normal operation to 1.5+ hours on dynamic operations)
Several adjustments needed to be made:
- Elevator
 - Vice grips
 - Pressure scaler
 - Thumb wheel setting
 - Width using black knobs
 - Set guiderails (L shape figures)
 - Film & Film bar (controls film motor and speed)
 - Set photo eye to scan for 3x2x1 or 2x3x1 bulk units

Thus, the key point from this discussion is that trial runs and adjustments consume a significantly large amount of Alcon production time, and they are performed by one key, experienced mechanic. Also, because there are two whitestock lines with needed adjustments performed by one mechanic, total changeover time has increased two-fold.

Some other inefficiencies occur with incorrect Madrid translations, such as unavailable warehouse components (i.e. package boxes and labels), packaging instructions, misplace of components and data. Thus, not all of the materials, such as labels and cartons, from the Bill of Materials are available or on-site for production. This development causes some major delays and production downtime. Also, usually after nine out of ten scheduled production batches, a problem emerges during production, such as wrong or unclear printed lot codes, improper training, and missing warehouse components. So, the production line has to be immediately stopped to resolve the issue at hand. Generally, whitestock lines have dynamic influences that may cause unnecessary production delays and increased changeovers.

In many established organizations, a most common problem is inadequate vertical or horizontal communication. In Alcon's case, the problem lies with inefficient vertical communication between functional divisions. For instance, the Alcon Marketing division, the Alcon Planning division, and the Alcon Manufacturing and Production (MP) division seem to be out of synchronization. Essentially, the Planning division acts as intermediaries between the Marketing and MP operations. The Marketing division requires certain products to be produced and shipped to the customer by a certain date. The Planning division purchases all of the materials and assigns a line to run a batch. So, usually, the MP division accordingly follows the predetermined daily production schedule (DPS), developed by the Planning division. However, in some cases, the DPS tends to go off tangent when the Marketing division requires a certain product to be produced immediately (special order) and informs the Planning division that production of a product must be completed by a certain date. The Planning division then changes the DPS and consequently offsets the current production for the whitestock lines. While the MP division has the whitestock lines currently producing the batch from the DPS, the whitestock lines must be stopped in order to accommodate this new customer order(s). Once production for the special order(s) has been fulfilled, then production from the previous batch may continue as scheduled on the DPS sheet. The MP division is usually informed of DPS changes at or next to the last minute. This particular behavior tends to add to the amount of changeovers that are performed in a day. Additionally, the Marketing and Planning division seems to lack hindsight over the difficulties involved with MP constraints or overlooks the types of problems that most often occur in production.

AMI: LONG-TERM APPROACH

Our proposal to implement the "Flex Line" layout are based on the observations that we have gathered from watching the physical and recorded overall changeover and operational processes, particularly Kits 1 and 5 and Lines 8 and 9. In idealistic terms, setting this concept and layout into place would enhance long term production efficiency. Some of the theoretical benefits include decreased product handling and movement, increased flexibility and productivity, as well as overall improved organization. In addition, further analysis and research would be recommended in terms of costs, equipment, and feasibility requirements.

One of the main benefits of the “Flex Line” is decreased product handling and movement of whitestock. The current two-step process incurs a large amount of time, energy, and preparation spent moving and transporting whitestock from one location to another to be filled, stored, labeled, etc. The newly attached filler would allow for in-line production of products on Kits 1 and 5. This would also decrease storage and inventory needs, which would increase availability of resources, in terms of cost and space.

The increased flexibility of Kits 1 and 5 would enhance the capabilities of production. The “Flex Line” makes the area more versatile in that it allows for multiple operational alternatives and use cases. Batches can be produced in-line as well as completed in a two-step process. This incorporates integration and cooperation of the two kit lines, while interference of operations is not an issue. The two lines sharing one set of equipment does not sacrifice production or organization, due to the independent characteristics of the layout. Further increased efficiency can be easily accomplished with effective product scheduling and planning.

The addition of a filler to Alcon’s facility would inherently increase productivity levels. It is apparent that when the filler is not in use or in operation, production quantity is sacrificed. The abundance of product that is run on the two kit lines would put the filler in steady use, thereby increasing the productivity and capacity of the entire facility.

The introduction of a flex pack line would add automated insertion of literature packets and/or lens cases. This would eliminate the need for manual insertion, thereby decreasing human error and increasing the speed of operations. Human resources would also be more readily available for utilization in other areas of operation.

With levels of production at its high, combining the short term changeover solution with the long term solution would minimize the downtime incurred with setup and changeover. Since the Kit 1 and 5 area is perceived as having the most inefficiencies, incorporating both concepts would help Alcon achieve maximum operating efficiency.

V. CONCLUSION

As a result from our in-depth analysis and observations, we have appropriately developed a short-term and long-term solution for Alcon Labs.

A. RECOMMENDATIONS

SHORT-TERM SOLUTION

Utilizing the SMED method approach, a good start to cut changeover time would be to implement advanced preparation of operating conditions (storage materials, tools, and parts). Alcon Labs maintains this approach very well (at 10% consumption of changeover time) by allocating space for storage, such as the staging area and the finished goods area for both whitestock line 1 and whitestock line 2. However, this approach can be streamlined further by allocating secondary spaces (see Exhibit 6). Currently, production whitestock line spaces are separated by a blue tape. We can further allocate space to include raw materials for the current batch (surrounded by green tape) and also allocate space for the palletizer (surrounded by green tape). We choose green to signal “Go.” Then, we can also allocate space for preparing raw materials for the next batch (surrounded by red tape, signaling “Stop”) while at the same time ensuring that the raw materials match the items on the MBR and the Bill of Materials. By allocating spaces, we reduce line clearance time by quickly looking for the green areas to see if the product has been fully cleared from the area while at the same time change the necessary product information on the line. We also save time by preparing raw materials early for the next batch (moving the raw materials from the staging area to the red boundary area). When the post-line clearance has completed, the raw materials for the current batch will then transfer to the green area, indicating the items are ready for production.

Alcon Labs should also ensure all items from the Bill of Materials arrive on-site and are ready for production. If not all items are available, a contingency plan should be developed in case a batch cannot be produced that day. For instance, a contingency plan would state production will continue and move forward to another batch as listed in the DSP, given that its MBR and Bill of Materials are prepared and ready for production. Rather than preparing for a single batch, we should prepare for the current and the next planned batch. By sustaining a continuous workflow on the whitestock lines, overall productivity would either remain the same or increase versus zero productivity for a total shut-down of the entire system.

Exhibit 6: Whitestock Line 1

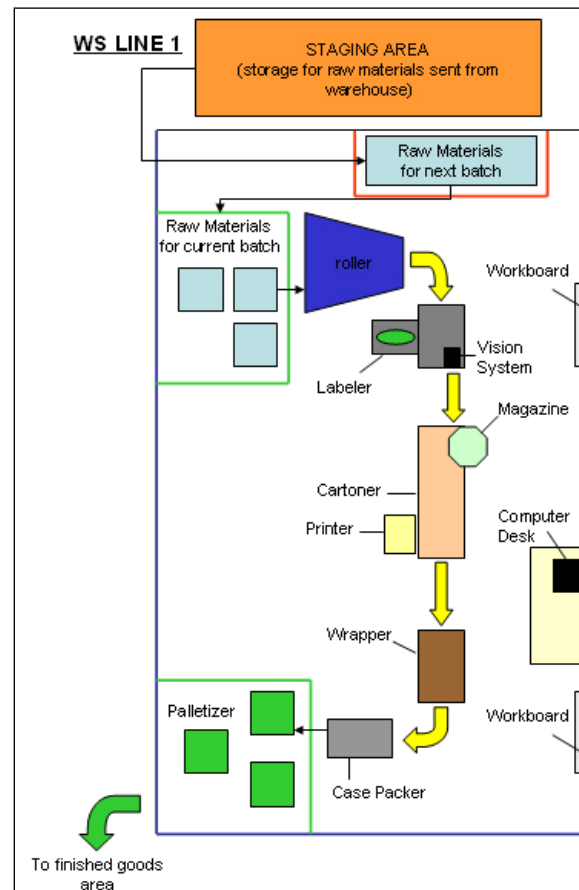

One of the most unnoticed organizational problems deals with lack of proper coordination between divisions or communication tensions at the employee as well as the manager level. In Alcon Labs, we should establish better protocols and attitudes towards working together as part of an “integrated” team effort, especially with the Marketing, Planning, and MP divisions. As we solicit more input from each other to obtain more thoughts, the more we generate options. So, teamwork should not only exist within divisions, but also exist between divisions. By collaborating amongst each other, unanticipated DPS changes will resolve to a mediate level and the “silo” mentality (a division acts and decides alone) will dissipate. Ideally, we should encourage practical teamwork exercises, define and prioritize issues, brainstorm solutions, and commit to a plan of action.

Exhibit 7: Changeover Process Improvement

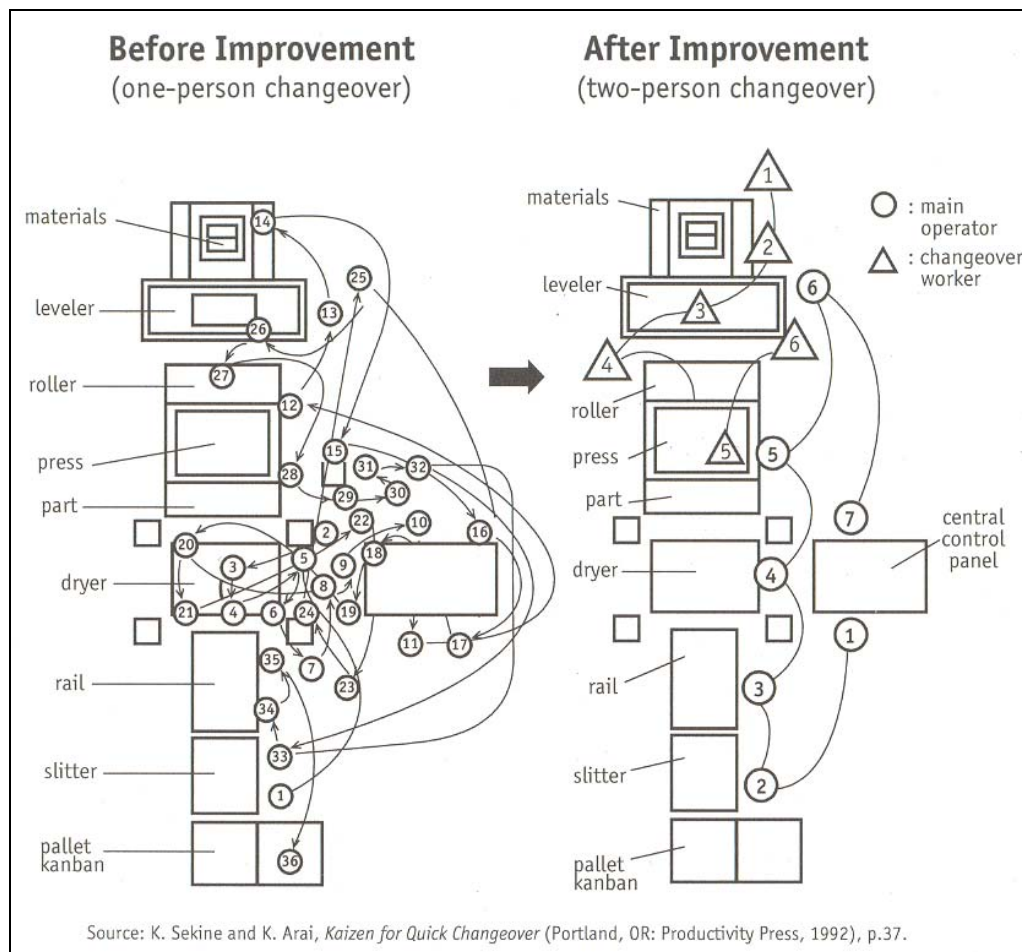

Most importantly, a strategic method to extensively tackle total changeover time will be to establish a Changeover team of four to five members, placed in tactical locations of the lines. Currently on whitestock lines one *and* two, only one mechanic performs measurements, settings, calibrations, and trial runs and adjustments. With one mechanic performing setup duties, total changeover time increases due to the number of unnecessary steps (see Exhibit 7). Please note that Exhibit 7 demonstrates one line on the left side; however, the true scenario at Alcon Labs involves two lines with one mechanic where the number of unnecessary steps has doubled. At times when total changeover time is expected to consume a longer amount of time, an additional two mechanics will assist the whitestock mechanic.

We should continue this approach, but we should unquestionably establish a force that entirely tackles setup issues.

Further, line clearances require a thorough, visual inspection of the system⁴ and preparation for the next scheduled batch. According to the SOP for PLC and whitestock line personnel, usually two people are involved with this process – one changes and the other verifies the product information. Because the SOP for PLC tends to be a linear process, this process can be streamlined to a parallel process. For instance, both individuals can change and verify product information. One starts at the beginning of the line and the other starts at the end. Both make necessary product information changes and as they move towards the middle of the line, their roles are switched from changing to verifying each other's work. At the same time, both have the ability to perform other PLC procedures. Further, a third member may assist in this approach and will of course expedite the procedure. With this approach, Line Clearance (LC) time is expected to cut time in half and contributes to reducing total changeover/rollover time.

Additionally, cross-training personnel increases employee efficiency and contribute to reducing total changeover time. Currently, whitestock personnel are moderately trained in changing labels on the labelers. We particularly encourage this approach by including more members into the process and requiring them to perform other needed functions in the changeover process. By cross-training personnel, the functionality of each employee has increased their value and has positively promoted productivity.

After interviewing with the mechanic associated with the whitestock lines about adjustments, we developed a list of possible solutions that would help whitestock members, including mechanics, expedite and *streamline* (SMED stage three) the transition or changeover process. Our goal will be to eliminate adjustments as much as possible.

Labelers:

- Strategically place one person from changeover team
- Construct a built-in flexible and movable rail system for continuous bottle flow movement (imagine a bowling alley rail)
- Mark height settings accordingly to size and weight of bottle (for example, when a twelve ounce bottle is needed, the changeover team member may adjust the height accordingly to the marked setting)
- Relax on loading labels (frustrating the labels while loading may release unwanted tension in the labels)
- Setup externally if this section is not in use for the current batch
- Replace bolts with hinges (similar to a hinge holding weight lifting bars or see Exhibit 10)
- Perhaps, place the vision system before labels are placed on bottle (versus wasting time peeling labels off the bottles and unnecessary bottle rejection, which contributes to inventory waste)

⁴System includes Banders, Labelers, Cartoners, Wrappers, Tape Machines, Ink Jet Coders, Vision Systems, Eisai Inspection equipment, Palletizer, Multivac Blister equipment, Sentine Blister equipment, Kitting lines, Capper, Hoppers/Hoppmans, Conveyors, Case Packers/Case Erectors, Bottle blowers and Heat Tunnels, Bulk Pack Cell, Quality Assurance Work Station, Transition Area, Reject Bins, Elevator/Lorevater, and Check Weigher.

Cartoners:

- Strategically place one person from changeover team
- Schedule batch of similar dimensions of carton
- Convert screws and bolts to one-time tighteners
- Mark height settings accordingly to dimensions of carton and bottles (see Exhibit 8)

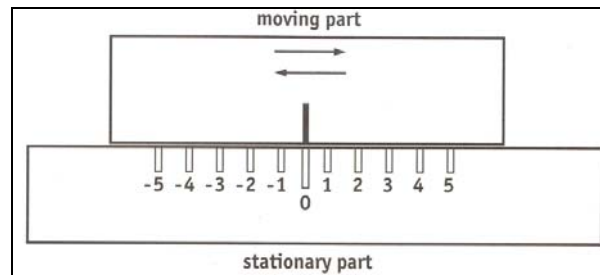

Exhibit 8: Settings

Shingo, 1996

Magazines:

- Strategically place one person from changeover team
- Convert screws and bolts to one-time tighteners
- Indicate on height settings accordingly to dimensions of carton and bottles

Ink Jet Coder:

- Strategically place one person from changeover team
- Convert this internal setup to external setup
- Input lot codes, expiration date, sublots, and ink insertion while external setup
- Mark height setting and placement of printer head onto line: build a puzzle slot to be placed on line for the printer head to smoothly fit in (see Exhibit 9 for an example)

Exhibit 9: Insertion Slot Source: Shingo, 1996

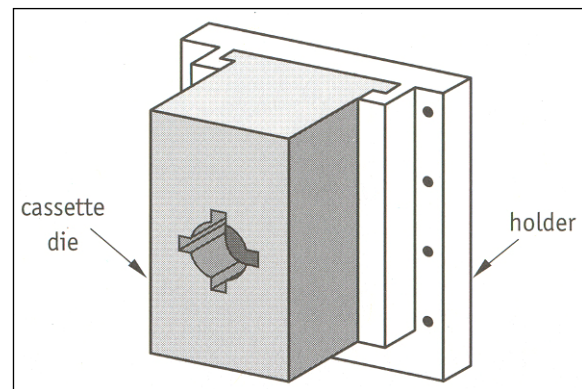
**Wrapper/Packaging:**

- Strategically place one person from changeover team
- Setup externally if machine is not in use for the current batch
- Mark necessary height settings accordingly to different products.

On a further note, we suggest that a DPS sheet should be given to the mechanics for updates, preparation, and anticipation for changeovers. In addition, according to the SMED, the use of bolts and nuts should be avoided because these fasteners slow down internal setup in a number of ways. Bolts get lost, get mismatched, and take too long to tighten. The SMED approach recommends using clamps as shown in Exhibit 10. Also, while there are setting bars located on the whitestock lines, we suggest utilizing them by marking lines to indicate

different settings that are associated with each product. During setup time, all adjustments are made by trial-and-error as well as intuition. With each changeover relying on intuitive adjustments, minutes and hours are wasted in order to finally achieve the proper adjustment. By indicating a setting for each product, adjustments can be completed in single-minutes.

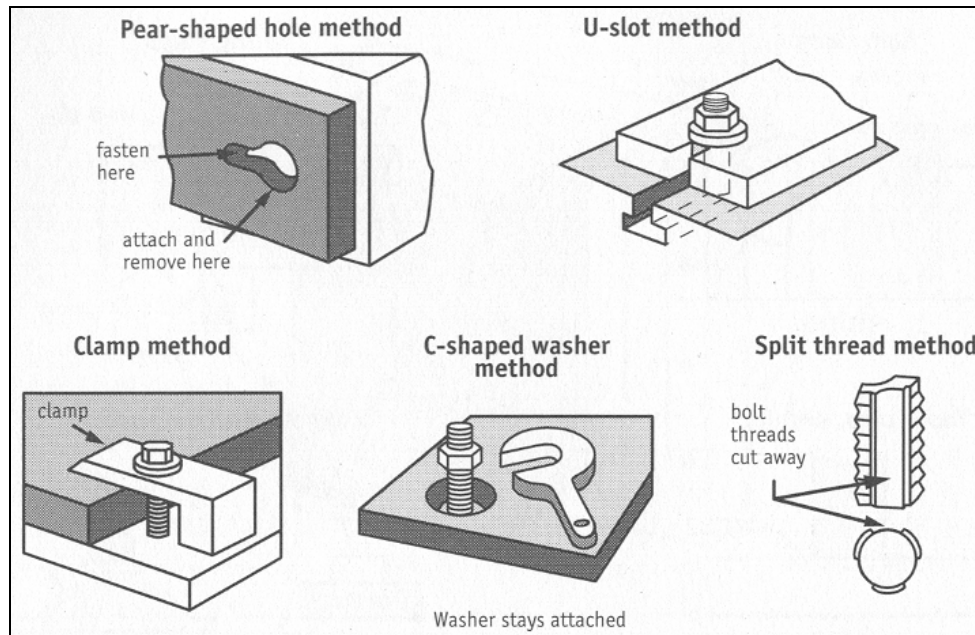

Exhibit 10: One-turn Functional Clamping Methods

Source: Shingo, 1996

Further, a frequent problem, according to the mechanic, occurs when adjusting the magazines and cartoner to fit the product cartons. We suggest incorporating function standardization, which keeps something the same from one operation to another. Function standardization (FS) should focus on standardizing functional elements essential to the setup rather than measuring external dimensions of every product. For instance, FS may apply to dimensioning, centering, securing, expelling or gripping on the whitestock line to fit accordingly to the product shape. As an example, we may apply shims to standardize height and clamping height. However, standardizing the dimensions of the carton size may allow for speedier adjustments.

In conclusion, with implementation of the SMED method and our possible list of solutions mentioned above, we will achieve significant reductions in total changeover/rollover time and increased productivity. Most importantly, we **strongly recommend** forming a changeover team in order to achieve these benefits.

LONG-TERM SOLUTION

Our recommendations for Alcon's manufacturing and Continuous Improvement Team would be to further analyze and research the possibility of putting the long-term solution plan into effect. The actual implementation of this particular "Flex Line" design will necessitate a more in-depth analysis with regard to costs, equipment and feasibility requirements. In order to develop a more precise model, an extended amount of time and resources would be necessary. The probable amount of time needed to conduct a thorough analysis would likely be approximately one year. Also, a team of people would need to be allocated to dedicate their time and labor into the successful execution of the project. The team that carries out the

research and implementation would also need to conduct a complete cost and payback analysis for the project, along with research into the various equipment alternatives. Feasibility requirements would need to be examined, with regard to such aspects as space, logistics, function, and performance measurements. Efficient production scheduling would also be an important and necessary supplement to the long-term approach. In summary, successful implementation of the project will necessitate very careful planning and further elaborate research. In the meantime, the short-term solution will still help Alcon Labs achieve their benefits and objectives, regarding whitestock production.

APPENDIX A: PROJECT SCHEDULE

CHART A

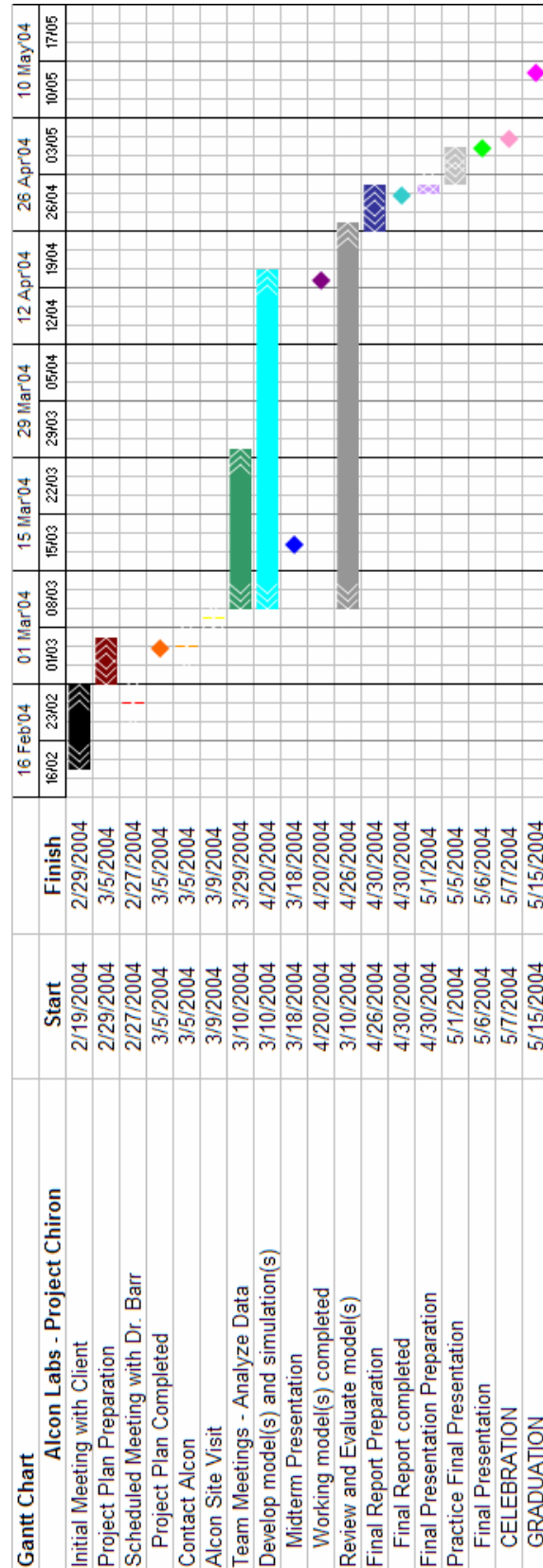

APPENDIX B: MODEL DOCUMENTATION

ProModel simulation software helped Team Alcon develop the current and new process simulation model as discussed in the Project Chiron report. The simulation files include CurrentK15.mod, NewK15mod, and a graphics library called, AlconPICS.glb.

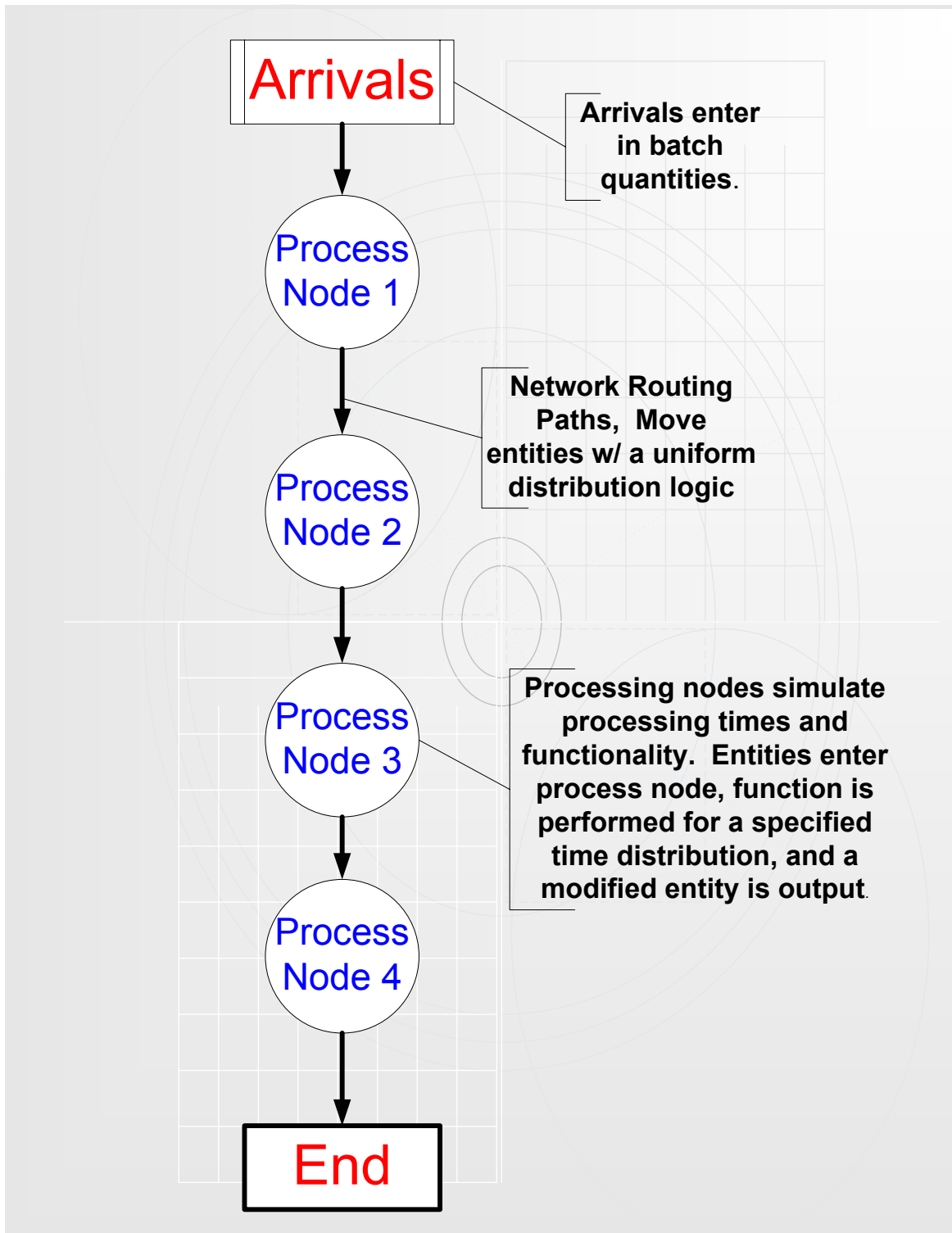

Current Kits 1 and 5 Process Simulation Model (CurrentK15.mod)

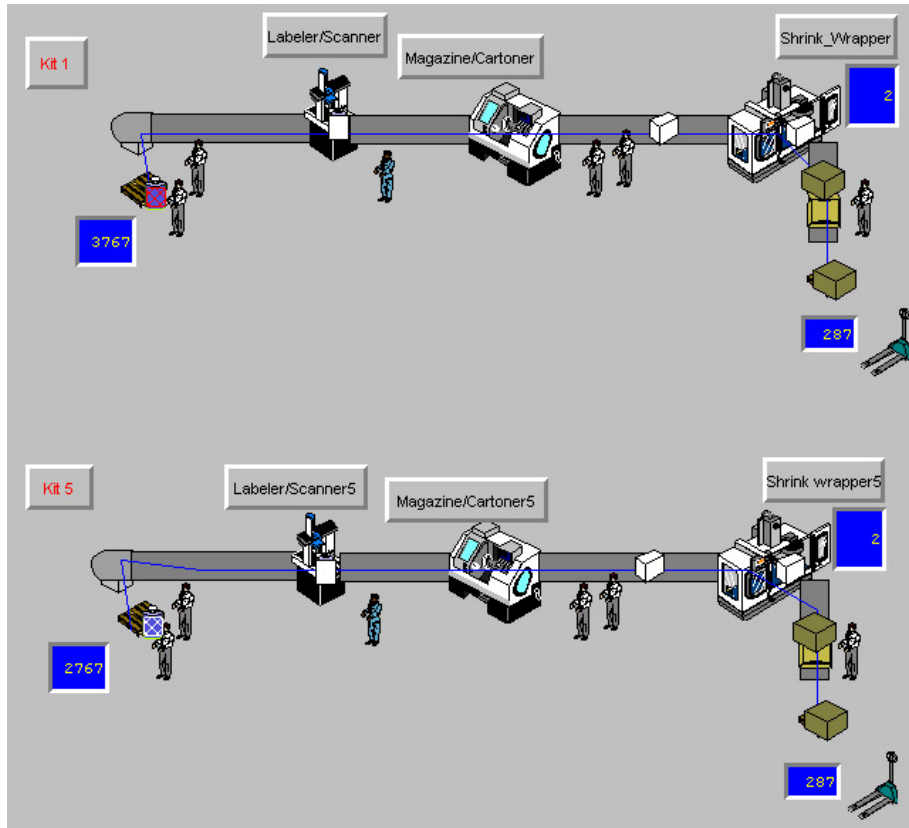

New Kits 1 and 5 Process Simulation Model (NewK15.mod)

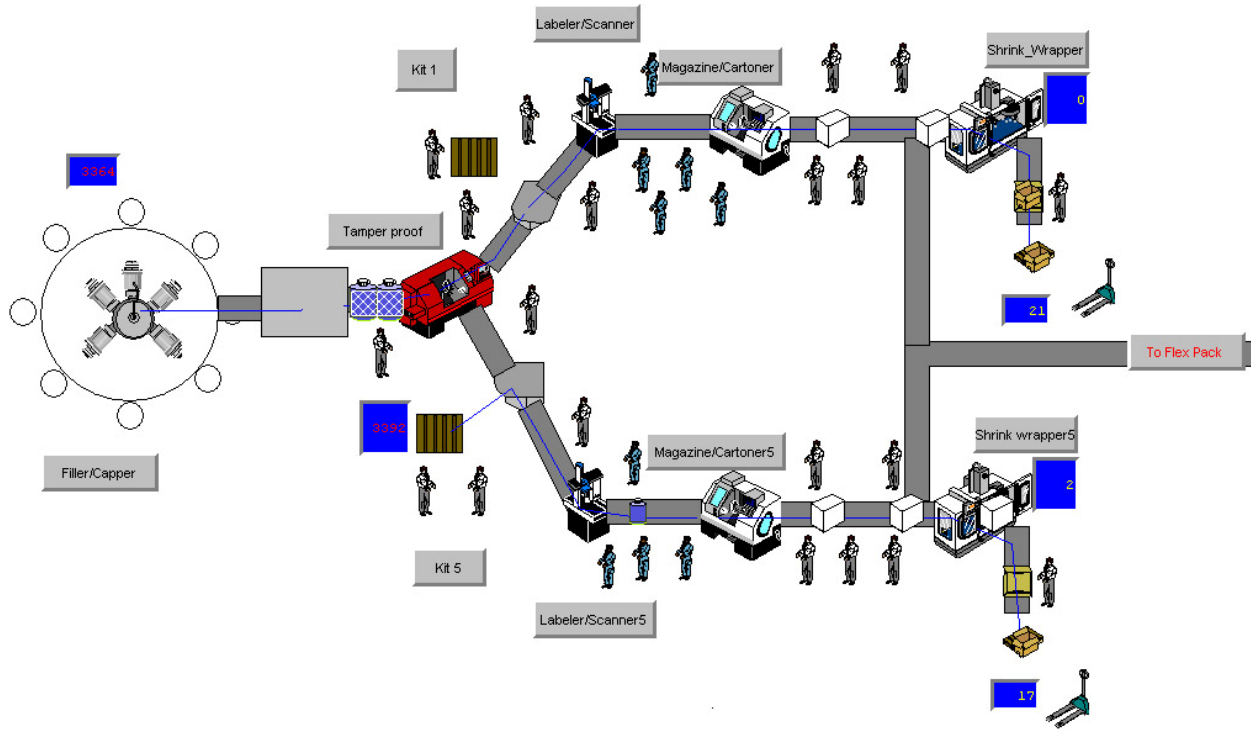

Current Kits 1 and 5 Process Simulation Results Sample		
Name	% Empty	% Part Occupied
Whitestock Pallet1	13.98	86.02
Labeler queue	96.14	3.86
Carton queue	93.93	6.07
Shrink wrap queue	71.11	28.89
Shrink wrapper	1.69	94.78
boxing queue	78.50	21.50
finished product pallet	0.06	99.94
Whitestock Pallet15	19.00	81.00
Labeler queue5	97.07	2.93
Carton queue5	95.04	4.96
Shrink wrap queue5	76.13	23.87
Shrink wrapper5	77.40	19.53
boxing queue5	82.40	17.60
finished product pallet5	0.06	99.94

New Kits 1 and 5 Process Simulation Results Sample		
Name	% Empty	% Part Occupied
filler	0.00	100.00
Fill Accumulation Queue	61.75	38.25
Kit1 queue	1.75	98.25
Accumulation1 Queue	92.37	7.63
Labeler queue	92.37	7.63
Carton queue	75.08	24.92
Kit5 queue	100.00	0.00
Accumulation5 Queue	100.00	0.00
Labeler queue5	50.61	49.39
Shrink wrap queue5	9.06	90.94
Shrink wrapper5	30.12	69.77
boxing queue5	92.01	7.99
finished product pallet5	52.52	47.48
Carton queue5	31.34	68.66
Shrink wrap queue	10.44	89.56
Shrink wrapper	30.35	69.64
boxing queue	85.42	14.58
finished product pallet	45.24	54.76
EmptyPallet5	0.00	100.00

APPENDIX C: EXCELLENT SUGGESTED READINGS

Reinertsen, Donald G. *Managing the Design Factory: A Product Developer’s Toolkit*. The Free Press: New York, 1997.

Shingo, Shigeo. *A Revolution in Manufacturing*. Productivity Press: New York, 1985.

Shingo, Shigeo. *Quick Changeover for Operators*. Productivity Press: New York, 1996.

APPENDIX D: PRESENTATION SLIDES (see following page)